



ELEVARE
CERTIFIED PARTNER OF ARITCO



SWEDISH PREMIUM HOME LIFT

SWEDISH QUIETUDE

Swedish Innovation, Curated for You

Founded in Stockholm in 1995, Aritco was created with a vision: to make vertical mobility elegant, accessible, and future-ready.

With over 40,000 installations across more than 40 countries, Aritco lifts embody Scandinavian design and European-certified safety — refined for the homes of tomorrow.

At Elevare, we bring these innovations to life in Indonesia through personal curation. Every home is different — so we recommend the lift that truly fits your design, your family, and your future.

As a Certified Partner of Aritco, we don't just deliver premium products. We deliver visionary living with elevated experience — curated with trust, for years to come.

Contents

Swedish Quietude	2
The Screw-Driven Technology	4
Know Your Lift	6
Aritco HomeLift	8
Aritco HomeLift	10
Aritco HomeLift Compact	16
Aritco Access Series	24
Aritco HomeLift Access	28
Aritco PublicLift Access	30
Safety	38
Smartlift Ecosystem	40
Warranty	42
Elevare Care (After Sales)	43
Elevare Showroom	47

THE SCREW-DRIVEN DIFFERENCE

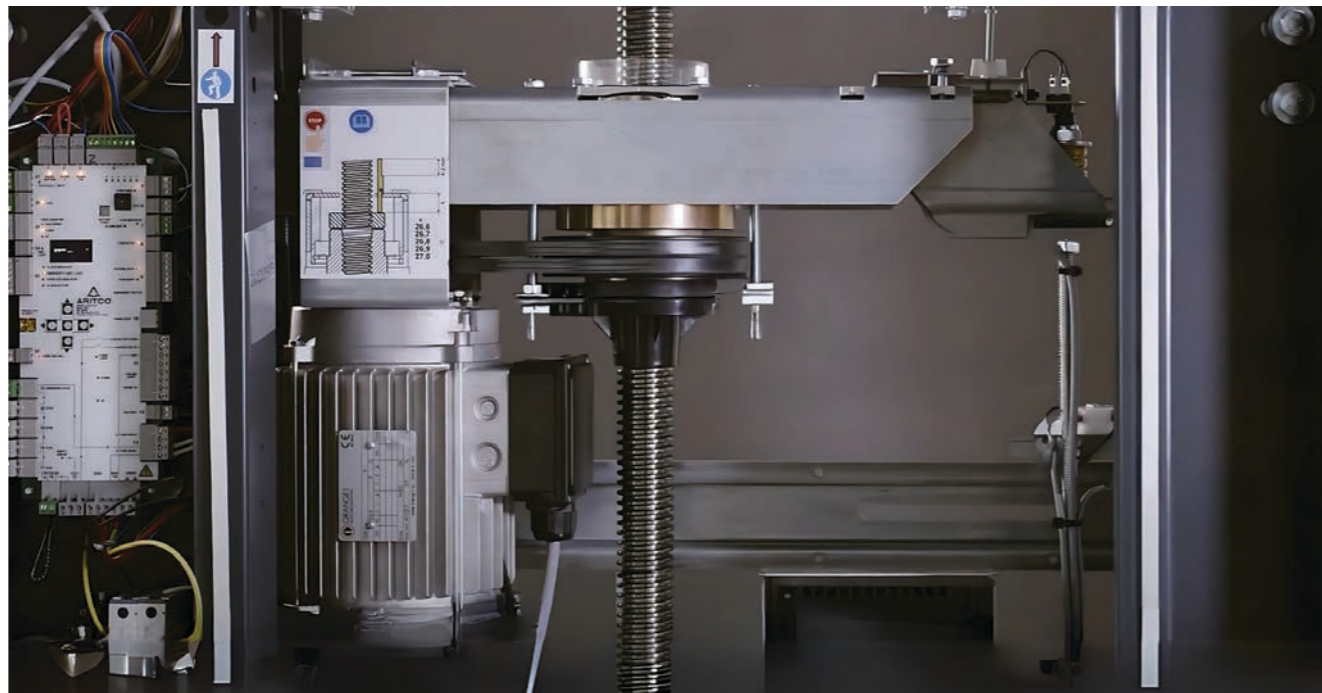

How It Works?

A robust steel screw runs the length of the shaft. A compact motor mounted on the platform turns a bronze nut, gently raising or lowering the car. This simple yet precise system operates without pulleys or counterweights — requiring only minimal lubrication to stay clean, quiet, and low-maintenance.



Discover the technology behind every Aritco lift.



Clean & Contained Mechanism

A discreet, enclosed system that keeps your home pristine — no mess, no visible machinery.



Self-Locking Safety

Designed to lock securely in place, even during a power outage — ensuring peace of mind.



Low Maintenance & Long Warranty

A discreet, enclosed system that keeps your home pristine — no mess, no visible machinery.



Smooth & Noise-Free

Rides are virtually silent — integrating effortlessly into modern living without disruption.



Compact Footprint

Requires no pit, no shaft, and no machine room, offering freedom to install even in limited spaces.

Backed by over 25 years of global installations, the Aritco screw drive system is proven across homes and buildings in more than 40 countries.

KNOW YOUR LIFT

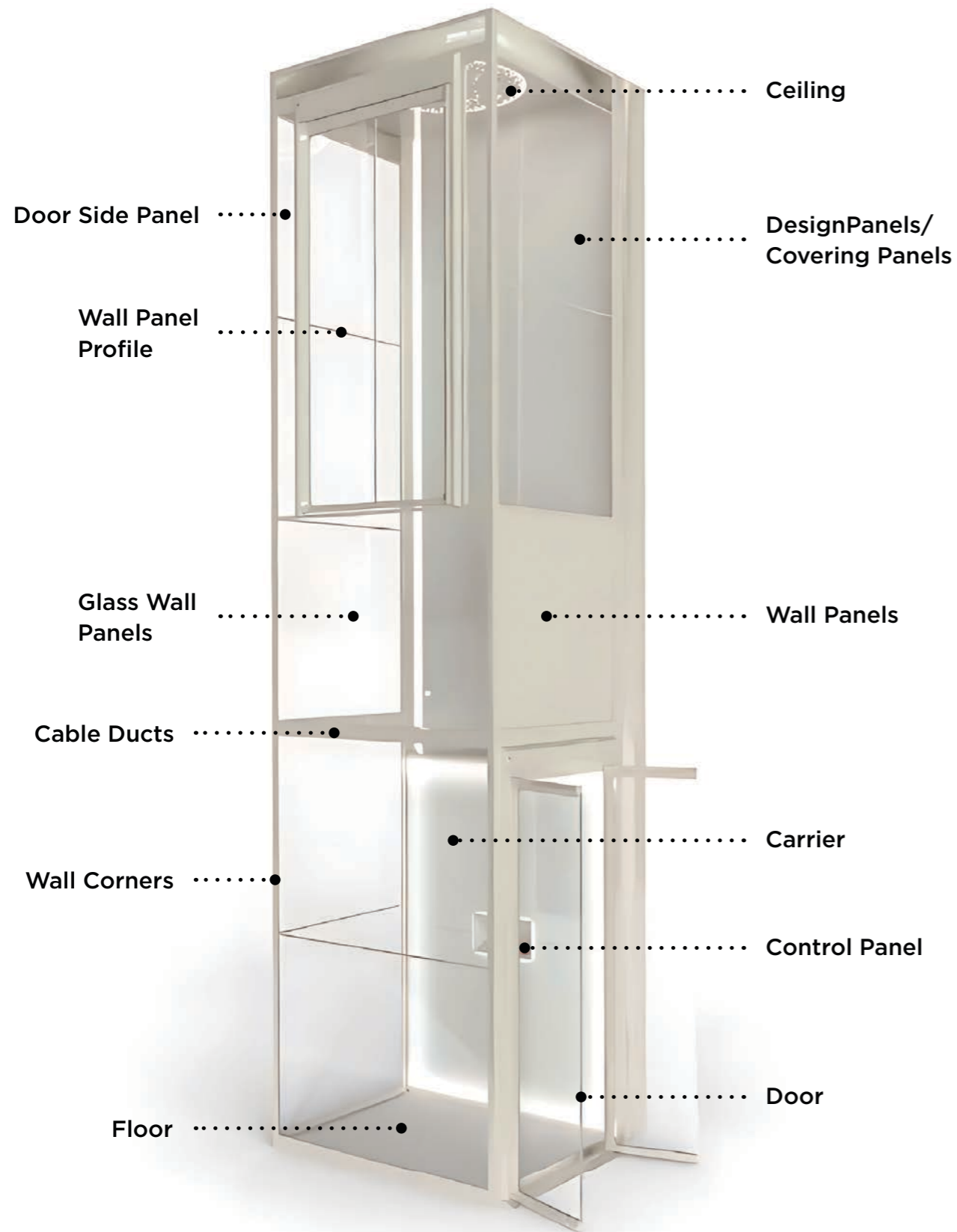

BUILT TO FIT

Every home is different — and so is every installation.

This is an overview of essential lift dimensions and how our system adapts to your space, both technically and aesthetically.

Wall Extention

Need extra height? Wall extensions in mm steps let the lift align perfectly with your ceiling for a seamless, tailored look.

Top Height

From floor to ceiling, top height defines how the lift integrates with your architecture — ensuring a clean finish with lighting discreetly concealed.

Travel Height

This is the vertical distance your lift covers — from one floor to the next — ensuring effortless movement throughout your home.

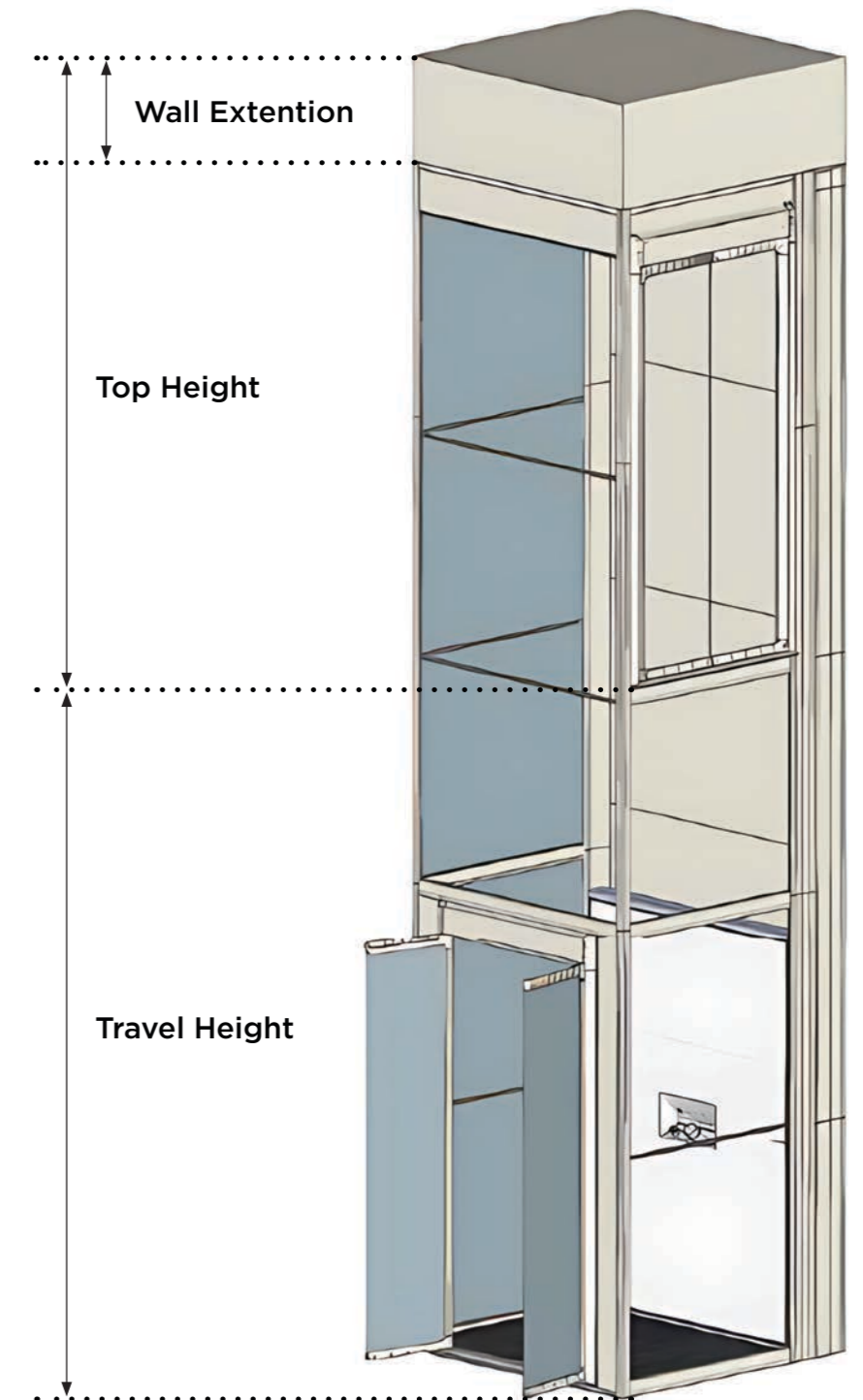

Aritco HomeLift

Aritco HomeLift is designed to be that extra feature of your home. It is decorative and is a spectacular design feature, which makes your home unique. It provides you with that extra feeling of luxury, and it ignites the full potential of your home.



Explore

Aritco HomeLift

Type of lift	Home lift intended for installation in private homes. Only to be used in buildings without public access.	
Technical compliance	European Machine directive 2 006/42/EC European standard EN 81-41	
Drive system	Screw and nut system	
Installation environment	Indoor	
Travel height	500 - 18 000 mm	
Top height	Minimum 2 225 mm. Wall extension 2 275 - 4 000 mm.	
Number of floors	2 - 6 floors	
Installation	Recessed installation with a 37 mm pit, or installed directly on the floor with a ramp	
Control from carrier control panel	One touch operation	
Rated speed (max)	0.30 m/s	
Power supply	230 V 1-phase, 400 V 3-phase	
Warranty	5-year product warranty and a 10-year drive technology warranty	
Carrier size and rated load	S5: 600 x 830 mm	250 kg / 2 pers.
	S8: 1 000 x 830 mm	250 kg / 3 pers.
	S9: 1 100 x 830 mm	250 kg / 3 pers.
	S12: 1 000 x 1 200 mm	400 kg / 5 pers.
	S15: 1 100 x 1 400 mm	400 kg / 5 pers.



The Carrier

The carrier is the moving part of the lift — a seamless L-shaped platform paired with the DesignWall. It glides quietly between floors, activated through the intuitive SmartControl on the control panel. Soft LED lighting ensures clear visibility, with 50 LUX at the floor and panel for a refined user experience.

DesignWall™

A signature element of the lift, the 2000 mm-high DesignWall is crafted from hard-coated, scratch-resistant acrylic glass and backlit with adjustable white LED.

It's a visual statement — customizable with curated patterns by Scandinavian artists to reflect your personal style.



SmartControl

SmartControl is more than just a way to operate your lift — it's a refined interface designed for clarity and ease. Located at the center of the DesignWall, this stainless-steel dial lets you select your floor with a simple turn and press. Subtle LED lighting ensures visibility, while the intuitive design feels as elegant as it is effortless.



16 Ways to Personalize Your Expression



16 Shades to Color Your Mood



4 Ways to Move with Style



9 Paths to Stand with Grace



3 Looks to Light Up the Sky

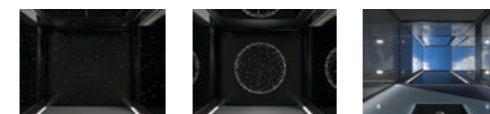

For other options & authentic material samples, please contact your Lift Advisor.

AWARD-WINNING HOME LIFT



reddot award 2017
winner



Design isn't just about aesthetics — it's about redefining how we live.

Crafted by renowned Swedish designer Alexander Lervik, Aritco HomeLift was envisioned not merely as a lift, but as a piece of furniture — seamlessly blending into the architecture of your home.



This vision has earned Aritco HomeLift international acclaim, with design awards celebrating its fusion of form and function.

- **Gold Winner** - Hong Kong Design Awards
- **Finalist** - Wallpaper Design Awards
- **Gold Winner** - International Design Awards

These recognitions reflect our commitment to combining elegant Scandinavian design, intuitive technology, and timeless functionality — making Aritco HomeLift not just a lift, but a design icon for the future of living.



SIZE

S5

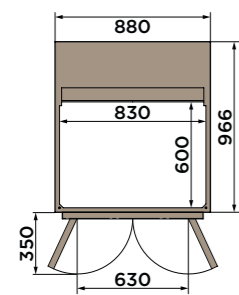
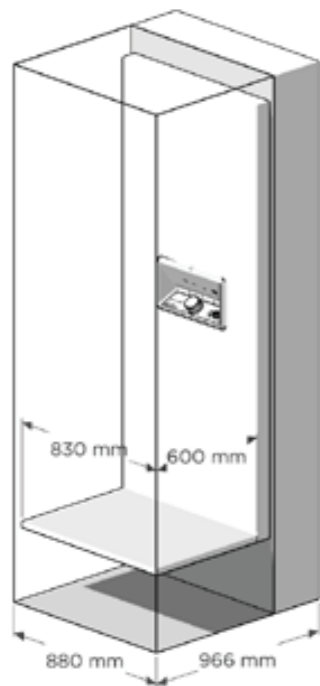

Size
S5

Carrier Size
600 x 830 mm

Wall Size
966 x 880 mm

Rated Load
250 kg / 2 pers.

S8

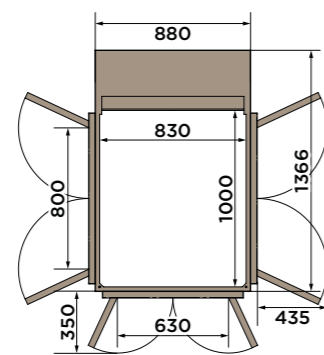
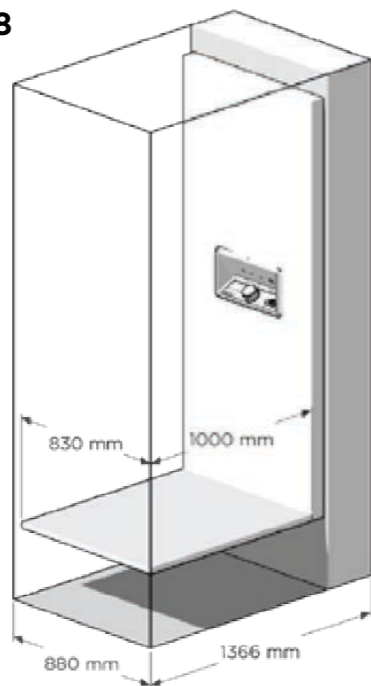

Size 
S8

Carrier Size
1000 x 830 mm

Wall Size
1366 x 880 mm

Rated Load
250 kg / 3 pers.

S9

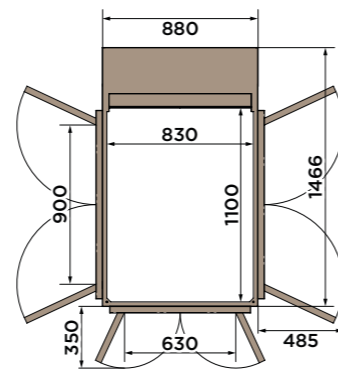
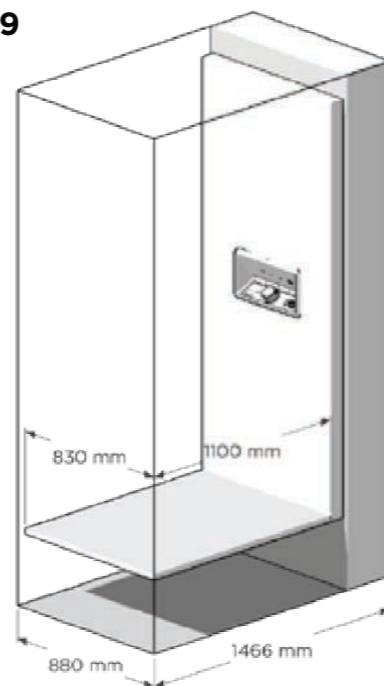

Size 
S9

Carrier Size
1100 x 830 mm

Wall Size
1466 x 880 mm

Rated Load
250 kg / 3 pers.

S12

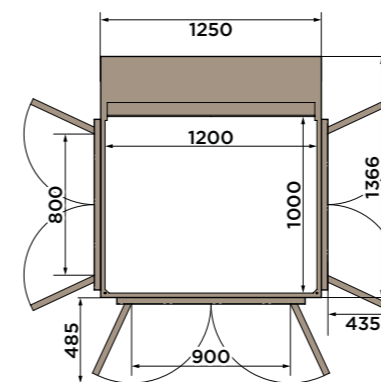
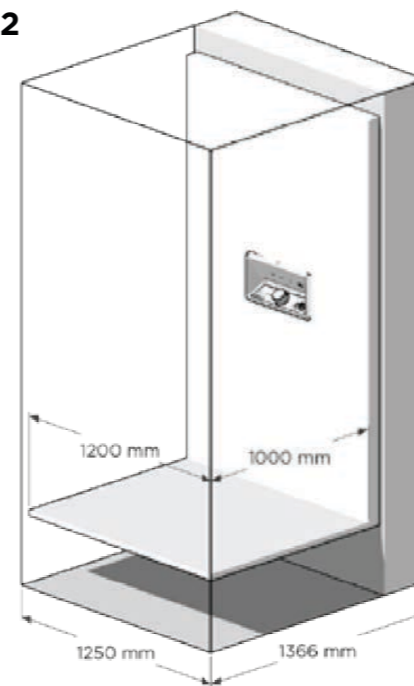

Size 
S12

Carrier Size
1000 x 1200 mm

Wall Size
1366 x 1250 mm

Rated Load
400 kg / 5 pers.

S15

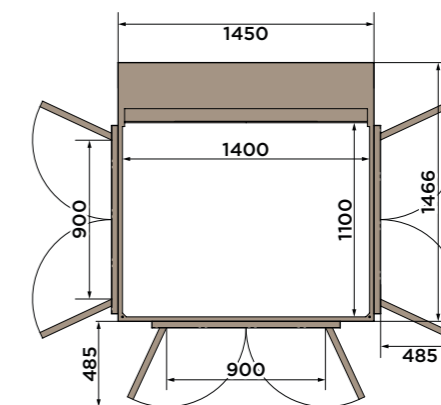
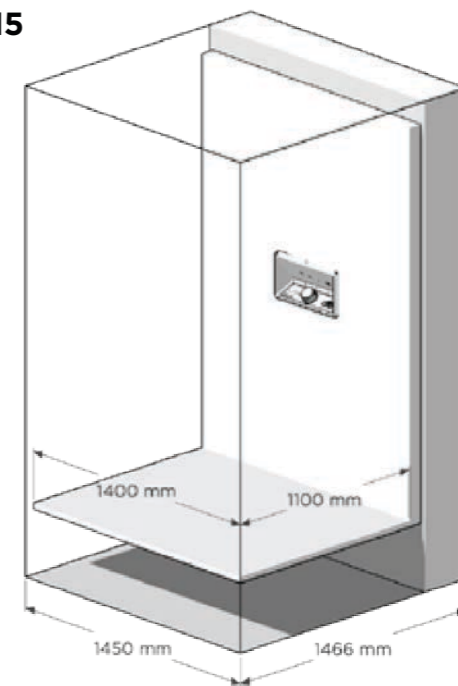

Size 
S15

Carrier Size
1100 x 1400 mm

Wall Size
1466 x 1450 mm

Rated Load
400 kg / 5 pers.

Aritco HomeLift Compact

Aritco HomeLift Compact is designed for homes that need a lift — but have limited space. With its sleek and minimal footprint, it fits discreetly into tight layouts without compromising comfort or design. It brings accessibility and style together, enabling smart living in a smaller scale.



Explore

Aritco HomeLift Compact

Type of lift	Home lift intended for installation in private homes. Only to be used in buildings without public access.	
Technical compliance	European Machine directive 2 006/42/EC European standard EN 81-41	
Drive system	Screw and nut system	
Installation environment	Indoor	
Travel height	1 600 - 15 000 mm	
Top height	Always 2 248 mm	
Number of floors	2 - 6 floors	
Installation	Recessed installation with a 50 mm pit, or installed directly on the floor with a ramp	
Control from carrier control panel	One touch operation	
Rated speed (max)	0.15 m/s	
Power supply	230 V 1-phase	
Warranty	5-year product warranty and a 10-year drive technology warranty	
Carrier size and rated load	C1: 580 x 805 mm	250 kg / 1 pers.
	C2: 880 x 805 mm	250 kg / 2 pers.
	C3: 1 080 x 805 mm	250 kg / 3 pers.



The Carrier

The carrier in Aritco HomeLift Compact features a full-height side wall that integrates a mirror, LED light cap, and SmartControl panel with handrail. Painted in elegant standard finishes or customizable RAL colors, it brings a clean and refined presence to any interior. Soft LED lighting at 50 LUX ensures visibility at the floor and panel, delivering both safety and sophistication in a compact form.

12 Ways to Personalize Your Expression

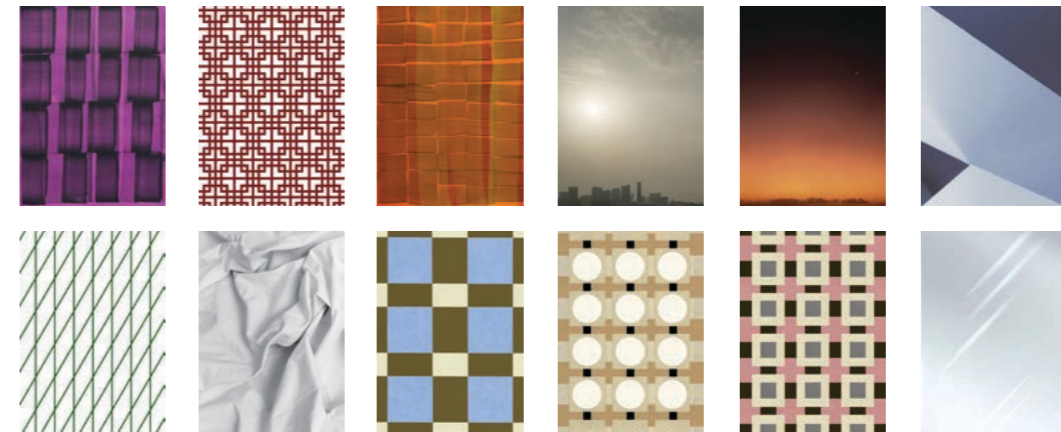

DesignWall™

The DesignWall offers a curated selection of artworks by Scandinavian designers, turning your lift into a personalized statement piece. Set behind glass, it blends functional elegance with artistic expression — with eight distinctive patterns to choose from.



11 Shades to Color Your Mood



8 Paths to Stand with Grace



Control Panel Front & Back

The control panel is split into two key sections: the front hosts the intuitive SmartControl and integrated handrail, while the back includes the emergency stop, alarm button, and capacity indicators.

2 Door Styles to Frame Your Arrival



For other options & authentic material samples, please contact your Lift Advisor.

DESIGNED FOR TIGHT SPACES

In today's homes, space is a luxury. Whether you're living in a compact townhouse, minimalist villa, or urban residence, **every square meter matters**.

That's why we created the Aritco HomeLift Compact — a lift that redefines what's possible in small spaces, blending Scandinavian design and technology into a solution that feels natural, effortless, and future-ready.





“Small footprint, Big thinking.”



Aritco HomeLift Compact is designed to be installed where others can't — even in existing homes with limited space and no lift shaft.

With a total footprint of less than 1 m², it can be placed in tight corners, corridors, or near staircases — without the need for machine rooms, deep pits, or major renovations.

This makes it the perfect solution for retrofits, renovations, and future-proofing your home — without compromise.

-  **Compact footprint for small spaces**
-  **Easy retrofit into existing structures**
-  **No pit, no shaft, and machine room-less**
-  **Works with any floor plan**

SIZE

C1

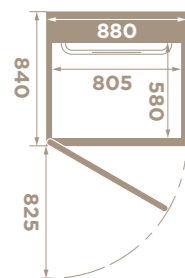
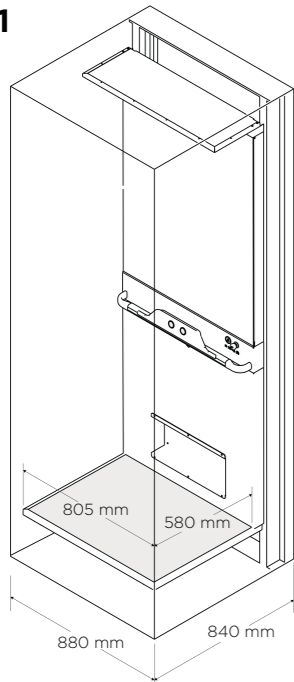

Size
C1

Carrier Size
580 x 805 mm

Wall Size
840 x 880 mm

Rated Load
250 kg / 2 pers.

C2

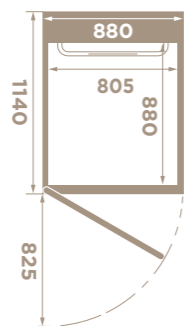
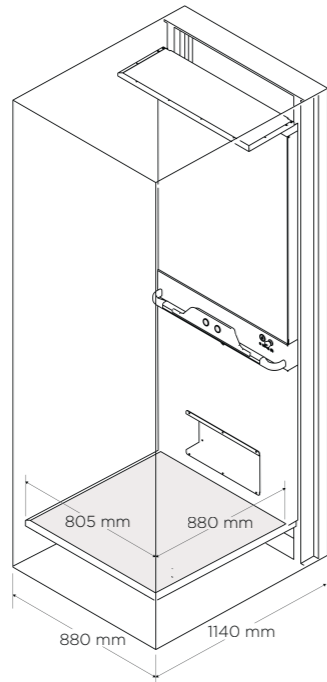

Size
C2

Carrier Size
880 x 805 mm

Wall Size
1140 x 880 mm

Rated Load
250 kg / 2 pers.

C3

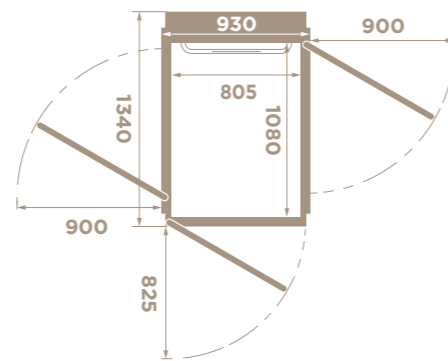
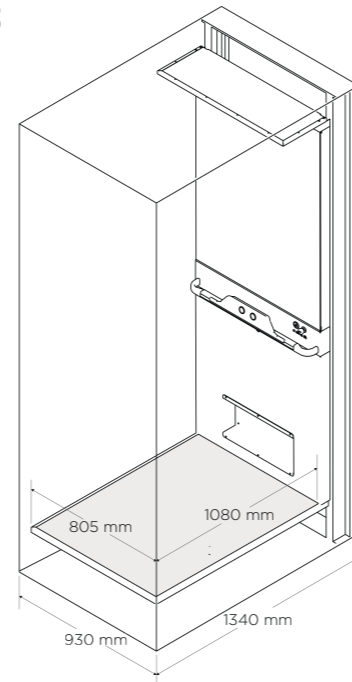

Size
C3



Carrier Size
1080 x 805 mm

Wall Size
1340 x 930 mm

Rated Load
250 kg / 3 pers.



Aritco Access Series

The Aritco Access Series is engineered for flexibility — whether enhancing accessibility at home or enabling public mobility with confidence. With the same trusted platform at its core, each model is adapted to suit its unique environment: the HomeLift Access for stylish private living, and the PublicLift Access for durable, code-compliant public use.



Explore

Aritco Access Series

Type of lift	Platform lift designed for use in private homes, public, and commercial environments.
Technical compliance	European Machine directive 2 006/42/EC European standard EN 81-41
Drive system	Screw and nut system
Installation environment	Indoor / Outdoor
Travel height	500 - 13 000 mm
Top height	2 240 mm - 4 000 mm 1 100 - 1 600 mm with half-height door
Number of floors	2 - 6 floors
Installation	Recessed installation with a 50 mm pit, or installed directly on the floor with a ramp
Control from carrier control panel	One touch operation
Rated speed (max)	0.25 m/s
Power supply	1-phase 230V 50 Hz / 16 A / 16 A slow 3-phase 230V 50 Hz / 9 A / 16 A slow 3-phase 400V 50 Hz / 5.2 A / 16 A slow
Warranty	5-year product warranty and a 10-year drive technology warranty
Rated load	250, 410, or 500 kg (depending on platform size)



**Aritco
HomeLift
Access**



**Aritco
PublicLift
Access**



The Carrier

The carrier in Aritco Access Series features a durable platform with a side wall — standard in half height, with an optional full-height wall integrating a mirror. It includes a SmartControl panel, handrail, and soft LED lighting (50 LUX) for safety and clarity. Finished in RAL 9016 (Traffic White), it can be customized in any RAL color to suit residential or public spaces.

Full-Height Wall

Available as an option, the full-height wall comes with a DesignWall™ for HomeLift Access — a backlit panel featuring Scandinavian artwork. For PublicLift Access, the wall includes a large integrated mirror for a clean, functional, and spacious look.



SmartControl

The control panel in Aritco Access combines intuitive function with refined form. Equipped with SmartControl, LED lighting, and safety features, it ensures ease of use at every ride. Choose between the Home or Accessibility version with large tactile buttons and braille — tailored for both private and public environments.



12 Ways to Personalize Your Expression

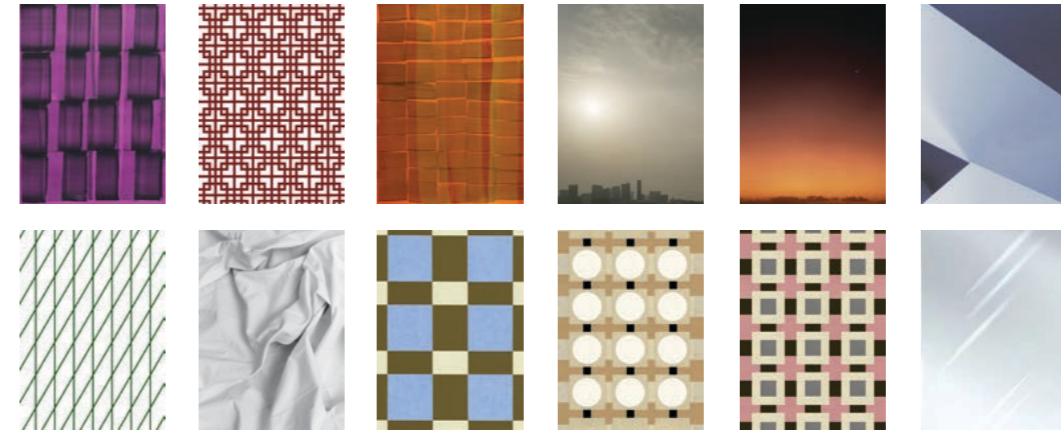

11 Shades to Color Your Mood



8 Paths to Stand with Grace



4 Door Styles to Frame Your Arrival



For other options & authentic material samples, please contact your Lift Advisor.



2 Wall Concepts to Define Your Space



11 Architectural Shades to Match Your Identity



8 Floors Finishes to Endure with Elegance



4 Door Styles to Welcome Every Visitor



For other options & authentic material samples, please contact your Lift Advisor.

OUTDOOR VERSION

Designed to Endure, Styled to Belong

The Outdoor Version of the Aritco Access Series brings safe, effortless mobility to terraces, gardens, and open-air entrances.

Built with weather-resistant materials, corrosion protection, and options such as roof, canopy, and heater, it delivers reliable performance year-round from -5°C to +40°C. With clear or tinted glass shaft panels and timeless Scandinavian design, it integrates seamlessly into any architecture, extending freedom of movement.



HALF-HEIGHT DOOR

When ceiling height is limited, the Half-Height Door provides a smart solution without compromising safety or design. Ideal for shorter travel distances, it ensures effortless accessibility while keeping the shaft height consistent and balanced.

Crafted with laminated glass and clean Scandinavian detailing, the Half-Height Door maintains a light and open expression. It is the perfect choice for homes or buildings that require an accessible lift within compact architectural conditions — combining practicality, safety, and timeless design.



SIZE

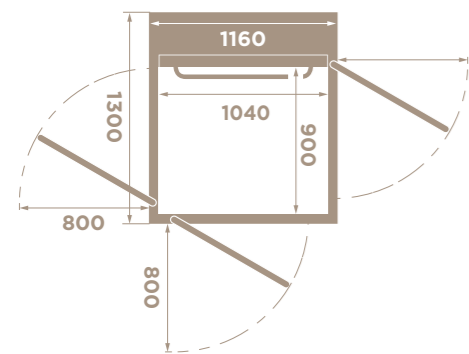
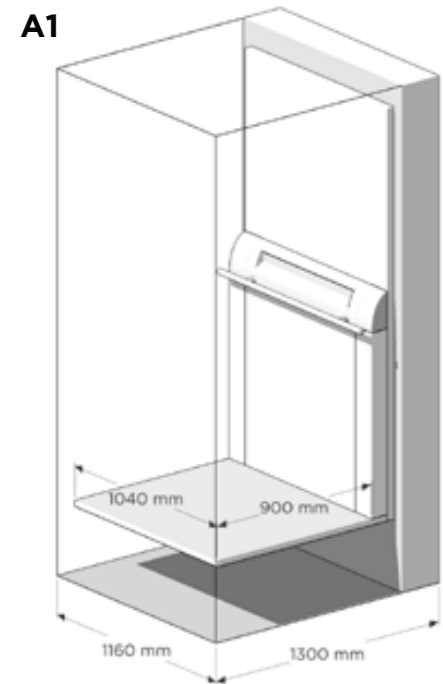



Size
A1

Carrier Size
900 x 1040 mm

Wall Size
1300 x 1160 mm

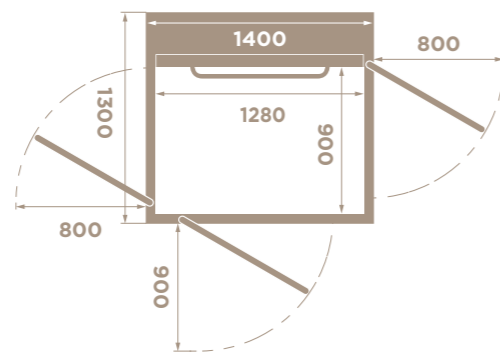
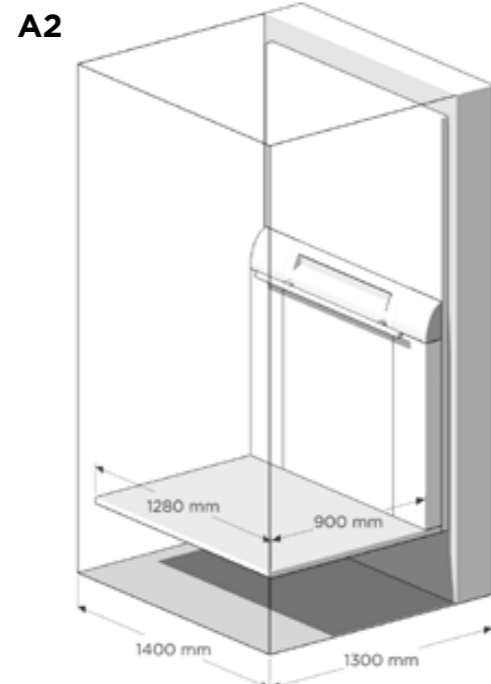
Rated Load
250 kg / 2 pers.





Size 
A2

Carrier Size
900 x 1280 mm

Wall Size
1300 x 1400 mm

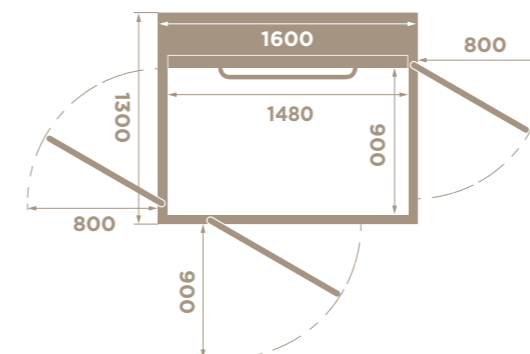
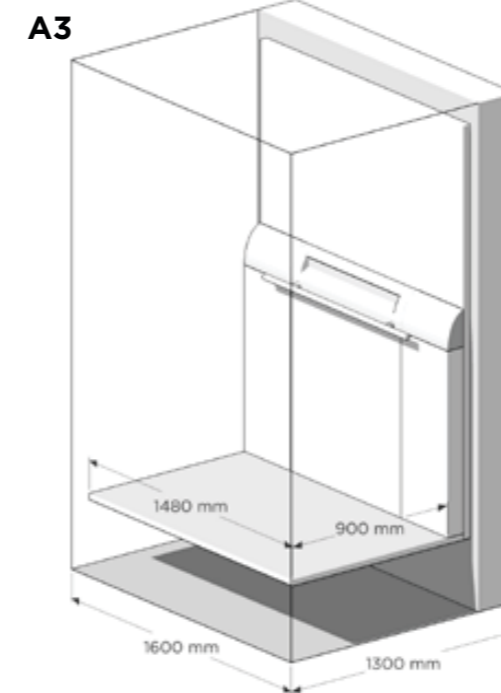
Rated Load
410 kg / 5 pers.





Size 
A3

Carrier Size
900 x 1480 mm

Wall Size
1300 x 1600 mm

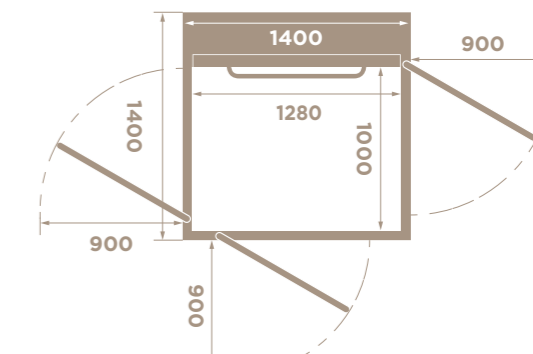
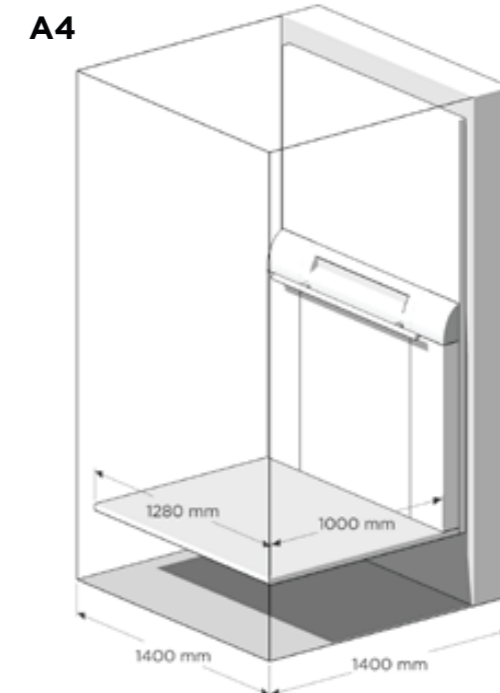
Rated Load
410 kg / 5 pers.



Size 
A4

Carrier Size
1000 x 1280 mm

Wall Size
1400 x 1400 mm

Rated Load
410 kg / 5 pers.

SIZE

A5

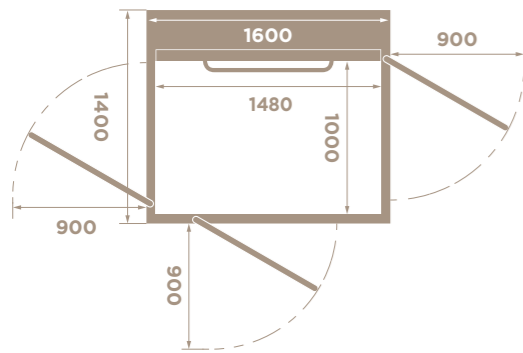
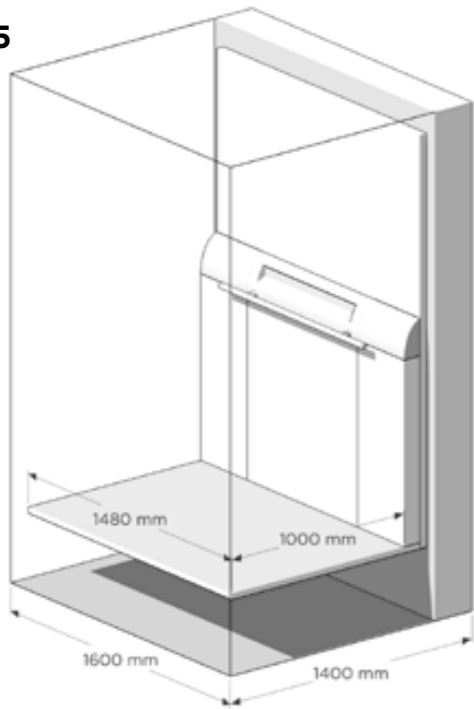

Size **A5** 

Carrier Size
1000 x 1480 mm

Wall Size
1400 x 1600 mm

Rated Load
410 kg / 5 pers.

A6

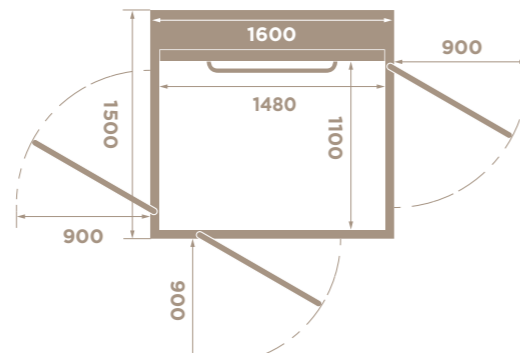
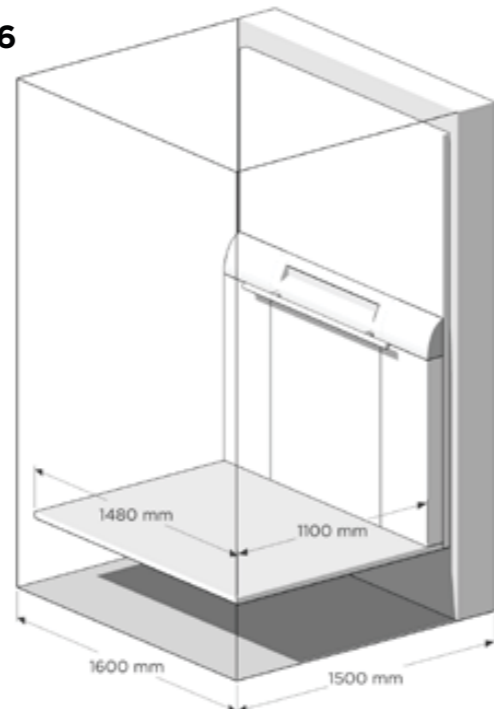

Size **A6** 

Carrier Size
1100 x 1480 mm

Wall Size
1500 x 1600 mm

Rated Load
410 kg / 5 pers.

A7

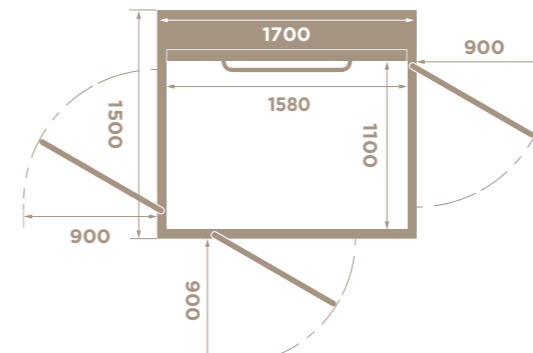
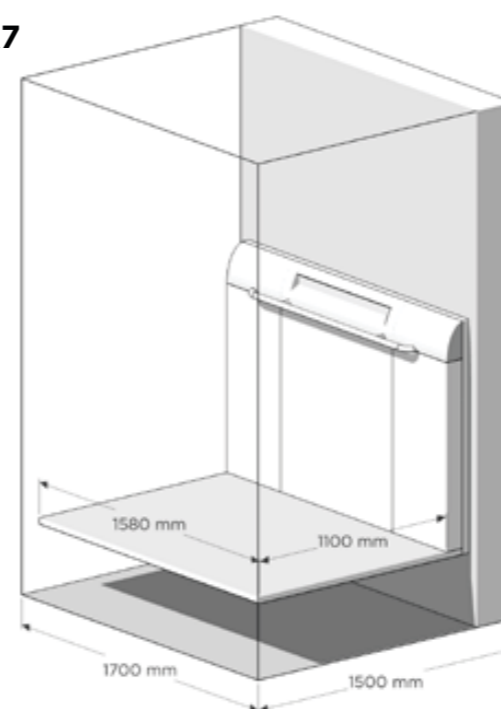

Size **A7** 

Carrier Size
1100 x 1580 mm

Wall Size
1500 x 1700 mm

Rated Load
500 kg / 6 pers.

A8

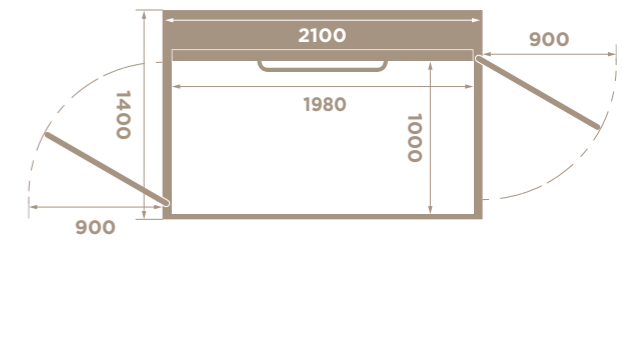
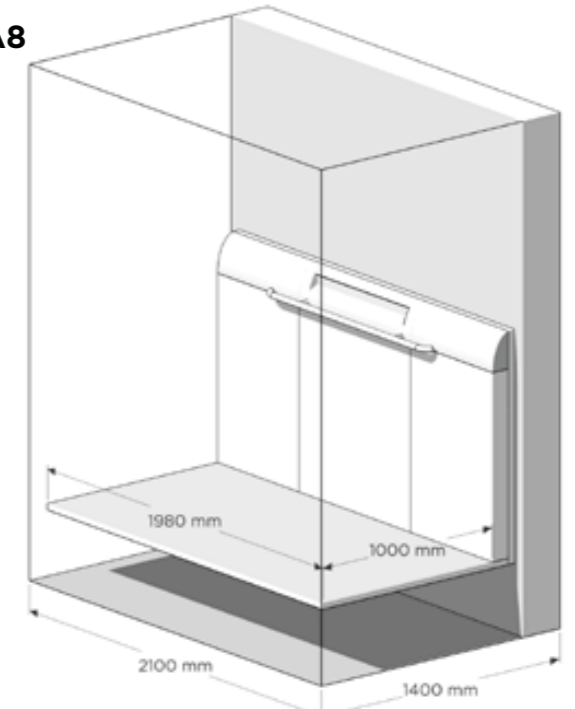

Size **A8** 

Carrier Size
1000 x 1980 mm

Wall Size
1400 x 2100 mm

Rated Load
500 kg / 6 pers.

BUILT-IN SAFETY

'Safety is not an add-on — it's engineered into every Aritco lift

Safety is the foundation of every Aritco lift. From the patented screw-and-nut drive to intelligent emergency systems, every detail has been designed to anticipate real-life situations and provide complete peace of mind.

Certified to the highest standards

All Aritco lifts comply with European directives and EN 81-41. PublicLift Access also offers EI60 fire- and smoke-proof doors, ensuring suitability even in demanding commercial environments.

Fail-safe mechanics

Our screw-and-nut system is inherently self-locking: the lift cannot fall, even without brakes. Dual safety brakes, overspeed governors, and safety nuts provide multiple layers of protection.

Emergency power and operation

In the event of a power failure, every lift lowers safely to the nearest floor with battery-powered emergency operation. Authorized personnel can also operate the lift externally via the service panel.



DAILY SAFETY

Safety is not only about engineering — it's about reassurance in daily use. Each Aritco lift comes equipped with features that protect & guide your journey.



Smart Door

Intelligent sensors make doors reverse when obstructed.

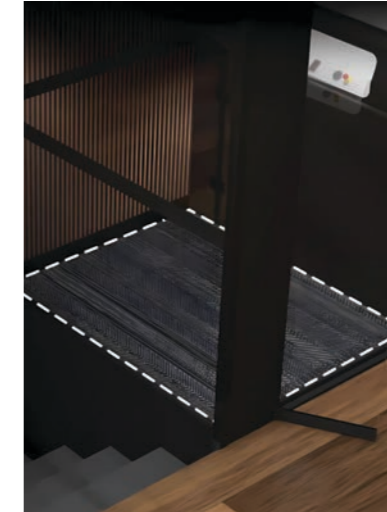

Safety Edge

Safety edges stop the lift instantly if anything is detected.

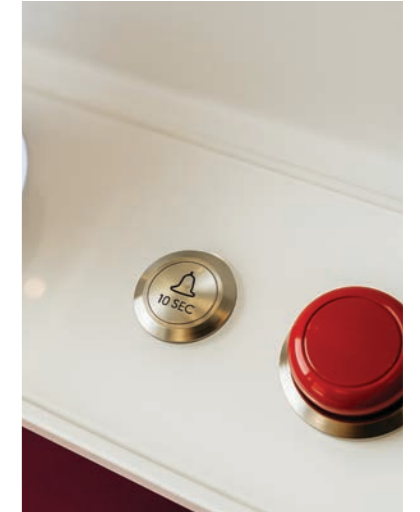

Emergency Call

An alarm button with 2-way communication in case of emergency.



Emergency Lowering

Battery lowers the lift safely during power failure.



Family Safeguards

Child-lock and floor-lock keep every family member safe with ease.

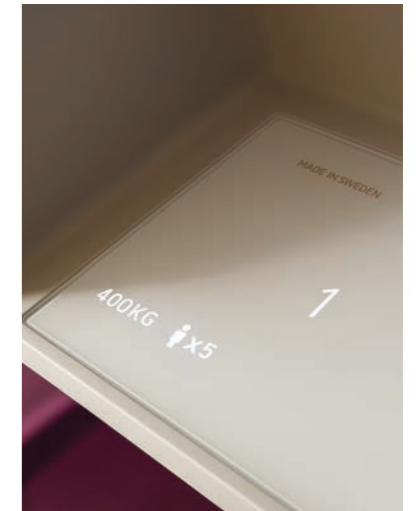

Overload Capacity

Lift stops and alerts when maximum load is exceeded.

SMARTLIFT ECOSYSTEM

Empowering lift ownership with insight and control.

With Aritco SmartLift, your lift is more than hardware—it's part of a connected ecosystem designed to enhance safety, predictability, and performance throughout its life.

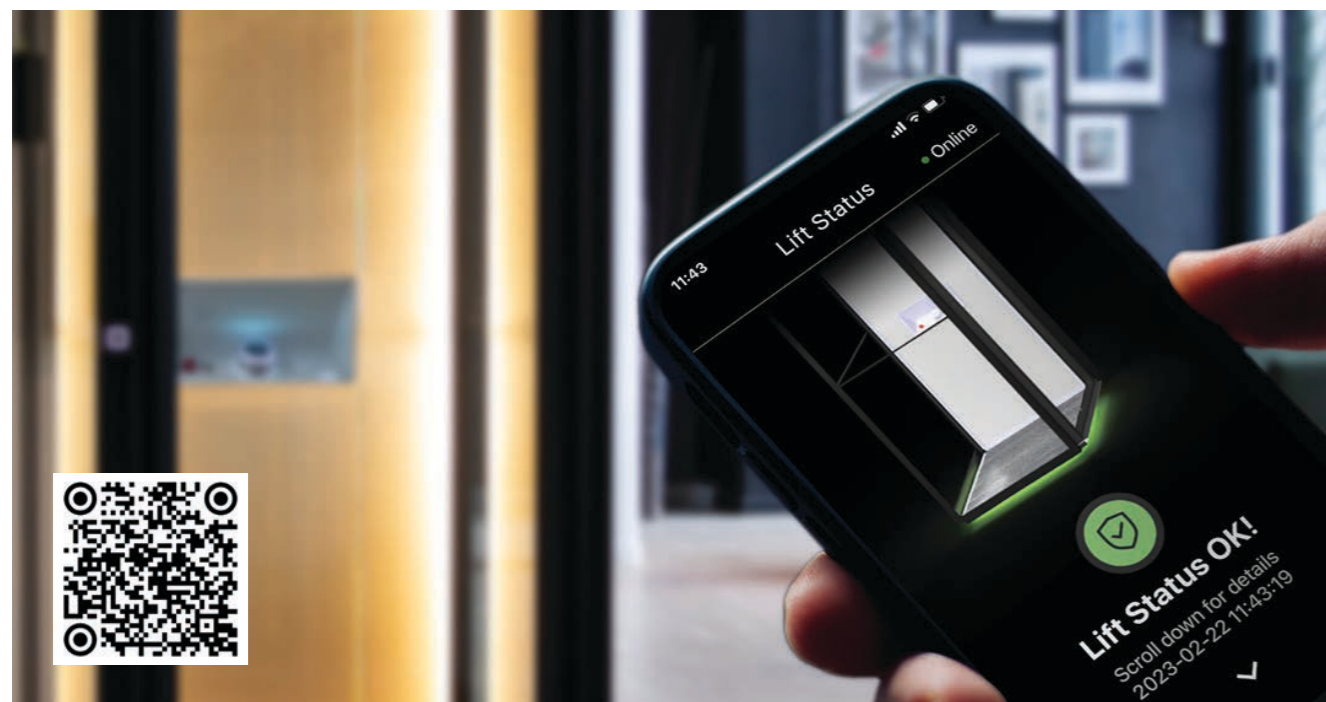

Lift Status & Safety Check

View real-time health, maintenance alerts, and safety status so you always know when action is needed.

Child Lock & Floor Lock

Control access instantly or on schedule via the app to block platform operations or specific floors for security and convenience

Lighting & Speed Configuration

Personalize the lighting modes — always on, fade, or energy-saving — and adjust travel speed where allowed.

SMARTAPP & SMARTFLEET

Remote insight. Proactive care. Together in one ecosystem.

Aritco SmartApp gives the homeowner control and visibility over their lift, while SmartFleet empowers service professionals to monitor, maintain, and support lifts remotely — ensuring smoother performance and fewer surprises.

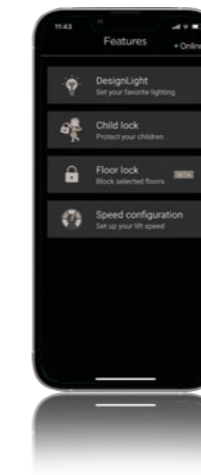

SmartApp Features

- Live status and maintenance alerts so users can see lift health at a glance.
- Child-lock & floor-lock scheduling to tailor access according your routines.
- Light modes & speed settings for personalization and comfort



SmartFleet Capabilities

- Remote monitoring of lift status, alarms, safety for proactive support.
- Log and alert system for service providers: usage, alarm, real-time faults.
- Remote software updates to keep functionality current and secure.

WARRANTY

Every Aritco lift is built to the highest European standards and backed by long-term warranties that reflect our confidence in design and engineering.



5-Year Product Warranty

All Aritco lifts come with a five-year product warranty — an industry first. This coverage guarantees against defects in materials and workmanship, provided installation and maintenance are carried out by Elevare. It reflects our commitment to world-class quality and long-term reliability.

10-Year Drive System Warranty

The technology of Aritco lift is the patented screw-and-nut drive, backed by a ten-year warranty. This exclusive protection underlines Aritco's confidence in its proven technology, ensuring safe and dependable operation for a decade and beyond.

ELEVARE CARE

At Elevare, we go beyond installation. Our Elevare Care+ program ensures every customer enjoys a seamless ownership experience with personalized support, proactive service, and dedicated maintenance for years to come.



+62 815-111-999-10



Chat with our
After-Sales Support



Preventive Maintenance

Five years of complimentary maintenance with scheduled inspections to keep your lift safe and reliable.



Lifetime Service

Genuine spare parts and professional service always available through our nationwide support network.



Proactive Care

Regular monitoring and preventive actions to ensure uninterrupted performance and peace of mind.

OUR SHOWROOM

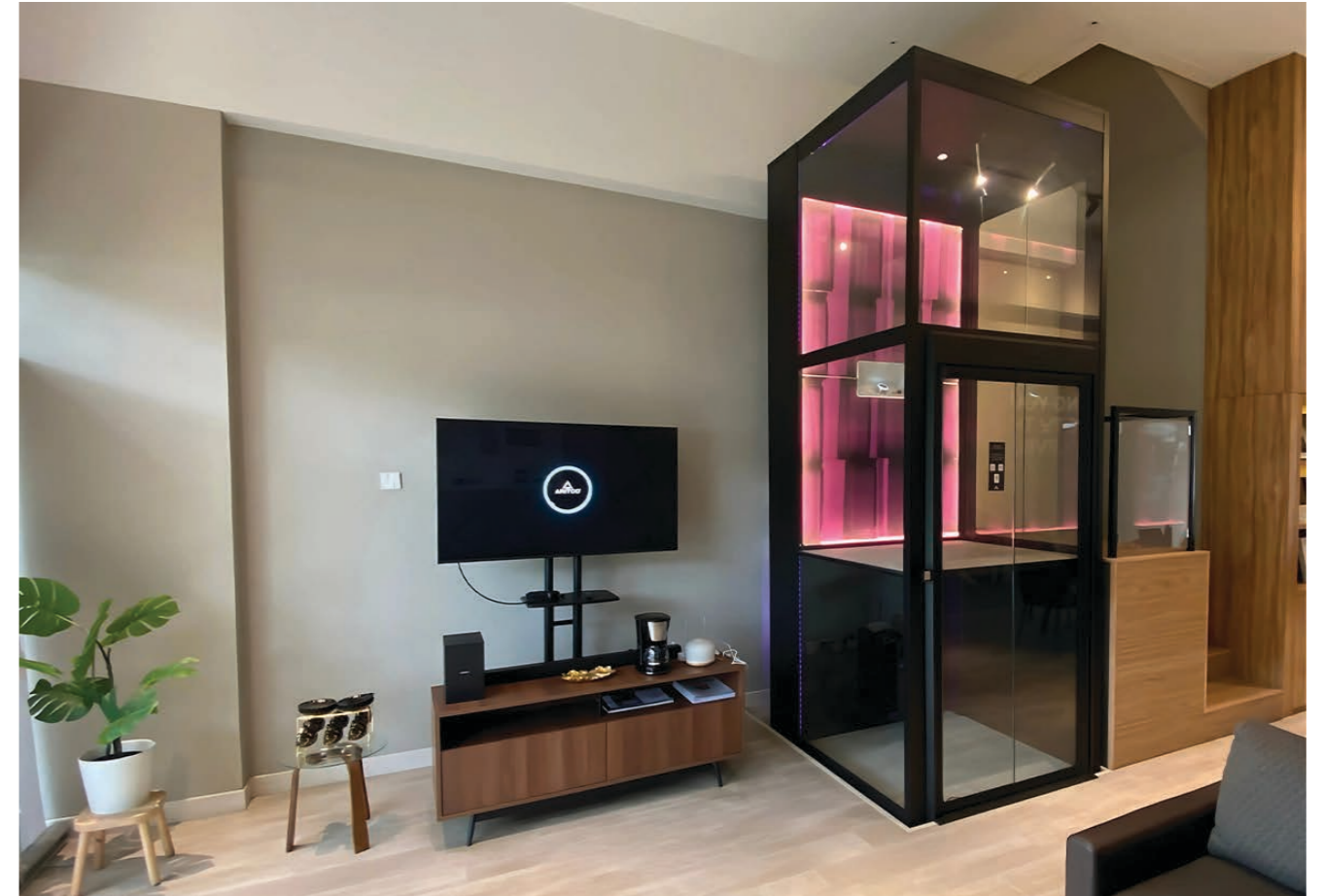

Step into our showroom and discover how Scandinavian design and technology come together in every Aritco lift. Here, you can experience the smooth ride, explore customization options, and consult directly with our team of experts.

Office hours

Monday : 08:30 - 17:30
Tuesday : 08:30 - 17:30
Wednesday : 08:30 - 17:30
Thursday : 08:30 - 17:30
Friday : 08:30 - 17:30
Saturday : (by appointment)
Sunday : (by appointment)

Visits outside the listed hours (include holidays) can be arranged by appointment.



Cleon Park No.32 Jl. Jakarta Garden City Boulevard
Cakung Timur, Cakung, Jakarta Timur, DKI Jakarta 13910

Sales & Marketing: +62 811-800-8012 | After Sales: +62 815-111-999-10



ELEVÁRE

CERTIFIED PARTNER OF ARITCO

Sales & Marketing: +62 811-800-8012

Elevare Care: +62 815-111-999-10

elevareindonesia.com